

SUBJECT:

**RESIDENTIAL METERING GUIDELINES FOR ELECTRIC SERVICE**

## **Meter Standards**

# **RESIDENTIAL**

**Metering Guidelines for Electric Service**

*August 2008*

---

REVISED:	PAGE:
8-1-08	2 of 22

SUBJECT:  
**RESIDENTIAL METERING GUIDELINES FOR ELECTRIC SERVICE**

**Residential Metering Guidelines for Electric Service**

**Table of Contents**

**Purpose**

Scope ..... 4  
 Disclaimer..... 4

**I. General**

**A. Advance Notice**

B. Automated Meter Reading ..... 4  
 C. Voltage, Phase, and Route of Service ..... 4  
 D. EUSERC ..... 5  
 E. Ownership ..... 5  
 F. Readily Accessible ..... 5  
 G. No Unauthorized Persons ..... 5  
 H. Connection ..... 5  
 I. Approval ..... 6  
 J. Disconnect ..... 6  
 K. Seals & Locking Devices..... 6  
 L. Load Balance ..... 7  
 M. Feedback ..... 7  
 N. Power Quality ..... 7  
 O. Company Poles ..... 7  
 P. Temporary Service ..... 8

**II. Meter Sockets**

A. Metering Voltages ..... 8  
 B. Mounting ..... 8  
 C. Openings and Drains ..... 8  
 D. Termination ..... 8  
 E. Safe Location ..... 8  
 F. Remote Meter Bases ..... 9  
 G. Meter Pedestals ..... 9  
 H. Clearances ..... 10  
 I. Meter Height..... 10  
 J. Taps and Splices..... 10  
 K. Un-metered Conductors ..... 10  
 L. Circuit Closing Devices ..... 10  
 M. Conductor Connection ..... 11  
 N. Meter Rings ..... 11

**III. Self-Contained Meters and Services**

A. Residential 200-Ampere Service ..... 11  
 B. Residential 320-Ampere Service ..... 11

**IV. Current Transformer Metering and Services**

A. Residential Services 400 and 600 Amperes Current Transformer Installation ..... 12

REVISED:	PAGE:
<b>8-1-08</b>	<b>3 of 22</b>

SUBJECT:  
**RESIDENTIAL METERING GUIDELINES FOR ELECTRIC SERVICE**

B. Secondary Wiring and Enclosure Requirements for Transformer Rated Meters..... 13  
 C. Landing Pads ..... ..13

**Drawings**

Drawing – Acceptable Meter Locations..... 14  
 Drawing – Typical Current Transformer Metering ..... 15  
 Drawing – Typical Underground Temporary Service ..... 16  
 Drawing – Typical Overhead Temporary Service..... 17  
 Drawing – Typical Underground Rec Vehicle Service..... 18  
 Drawing – Typical Underground Mobile Home Service..... 19  
 Drawing – Meter Clearance Guide ..... 20  
 DWG 328A – Current Transformer Mounting Base Single Phase Landing Pads Without Lugs ..... 21  
 DWG 328B – Current Transformer Mounting Base Single Phase Landing Pads With Lugs ..... 22



SUBJECT:

**RESIDENTIAL METERING GUIDELINES FOR ELECTRIC SERVICE**

**PURPOSE**

The purpose of this standard is to acquaint the customer with the requirements established by Peninsula Light Company, herein referred to as PLC, for the installation of electrical service to single-family residential homes.

**SCOPE**

This standard covers single-family residential electrical services of 120/240 volts single phase up to and including 600 amperes. All other services shall comply with PLC Commercial Metering Standards. Failure to comply with these standards may result in fines, fees and or termination of electrical service.

**DISCLAIMER**

National Electric Code (NEC) and PLC Standards have differences. NEC and PLC Standards are subject to change without notice.

**I. GENERAL**

**A. Advance Notice**

1. PLC must be consulted by the owner, the owner's agent, or the contractor making the installation, regarding the service entrance location and the meter equipment requirements before installing the service and equipment. Provisions for a meter and related equipment, an attachment of a service drop, or an underground service lateral must be made at a location acceptable to PLC.
2. Customers must complete an application for service form including an accurate load description and the projected date for service connection. All fees and costs associated with the project must be paid prior to construction.
3. The point of service drop must permit the clearances required by the NEC. WAC 296-46A-23001.

**B. Automated Meter Reading**

Peninsula Light Company operates an Automated Meter Reading system throughout the entire service area. This system continuously communicates with PLC Headquarters using the power lines. PLC has changed several policies regarding electrical meters, meter bases and the electrical service to each meter. The changes have been inserted into the appropriate area of this meter standard. Automated Meter Reading has NOT changed access requirements to the meters and related electrical equipment.

**C. Voltage, Phase, and Route of Service**

1. PLC reserves the right to determine the voltage, phase, and route of the service.
  2. 120-volt services (two-wire services) are not allowed.
-

SUBJECT:

**RESIDENTIAL METERING GUIDELINES FOR ELECTRIC SERVICE**

**D. EUSERC**

The Electric Utility Service Equipment Requirements Committee is a joint committee of utilities and manufacturers. This committee provides communication between utilities and manufacturers that help standardize and improve product design for electrical service equipment. Peninsula Light Company may refer to EUSERC drawing numbers to help customers and electrical suppliers purchase products accepted by Peninsula Light Company.

PLC updates the list of approved electrical equipment as necessary and forwards this information to several local electrical supply houses.

**E. Ownership**

1. PLC shall furnish, maintain and retain ownership of all watt-hour meters and instrument transformers.
2. Customer-owned equipment such as meter sockets, remote meter pedestals, enclosures, landing pads, conduit, and wiring must be installed and maintained by the customer.

**F. Readily Accessible**

1. In the express interest of providing the best possible electric service to all customers, PLC must have immediate 24-hour access (see definition below) to its facilities and equipment located on customer's premises. We make every effort to do our work with the least inconvenience to the customer.
2. When service connection is terminated, PLC may remove PLC-owned property from the customer's premises.

**Definition:** Capable of being reached quickly and conveniently 24 hours a day for construction, operation, maintenance, inspection, testing or reading, without requiring those seeking access to climb over or remove obstacles; or to obtain special permission or security clearances. Truck access may be required.

**G. No Unauthorized Persons**

1. The customer shall be responsible for PLC property on the customer's premises and shall not permit tampering with said equipment. In addition to the Meter Tampering/Diversion Fee established, any repairs and equipment damage to PLC property shall be billed to the customer of record.

**H. Connection**

1. PLC will be responsible for connection or disconnection of service between company power lines and customer-owned facilities. Only authorized employees or agents of PLC are permitted to do this work.
  2. The customer must notify PLC's Engineering Department when the State Department of Labor & Industries has approved a new service for connection.
-

SUBJECT:

**RESIDENTIAL METERING GUIDELINES FOR ELECTRIC SERVICE**

**I. Approval**

1. The customer's service conductors will not be connected by PLC until the Electrical Inspector from the State Department of Labor & Industries has approved the service for connection and the service has met PLC requirements.

**Exception:** On altered services where the power was disconnected to allow for said service upgrade or repair, the building was and remains occupied, and an electrical permit was issued and posted at the jobsite, service may be restored pending electrical inspection by the State Department of Labor & Industries, provided that the service meets PLC requirements. Failure to gain Labor & Industries approval in a timely manner may subject the service to immediate disconnection.

2. Jumpering of meter sockets by electricians or customers is **not** allowed for any reason.

**J. Disconnect**

1. Peninsula Light Company operates an Automated Meter Reading (AMR) system. Each meter in the system communicates continuously with our headquarters over the power lines. Electricians, Homeowners, Tenants or any other person(s) are NOT allowed to cut seals, and remove AMR meters or to de-energize the electrical service.
2. When it is necessary to disconnect PLC's service conductors or meter, the customer must call 253-857-1565 at least twenty-four (24) hours in advance.
3. All electrical work must be permitted by Washington Department of Labor and Industries before the work is started. PLC crews will not remove an AMR meter from a service without a posted permit.
4. If a meter removal or service disconnect is requested and there is no permit, a trip fee will be charged.
5. Permitted work must be approved by L & I within 48 hours of the time PLC reconnects the service. Electrical service will be disconnected if L & I does not approve the service.

**Caution:** With some types of meterbases, removal of the meter does not de-energize the service, and may cause damage to equipment and be dangerous to personnel.

**K. Seals & Locking Devices**

1. The seal is a bond of mutual protection for PLC and the customer. As such, it may not be broken by anyone but an authorized representative of PLC.

SUBJECT:

**RESIDENTIAL METERING GUIDELINES FOR ELECTRIC SERVICE**

2. All metering equipment must be sealable and lockable as determined by PLC's Meter Department.
3. All enclosures containing un-metered conductors or busing must be sealable and lockable as determined by PLC's Meter Department.
4. At the time of installation, the metering equipment shall be sealed and shall not be tampered with or the seal broken by anyone. Any tampering with the metering equipment or unauthorized breaking of seals can be considered an evidence of theft. Any person, who cuts PLC's seals and/or wrongfully obtains electric service by bypassing, tampering with, or modifying a meter, may be subject to criminal charges.
5. Locking devices are installed to help ensure meters are not removed. The customer is responsible for all damages that are the result of attempting to remove the meter and/or the locking device.

**L. Load Balance**

The customer or his contractor shall connect his equipment to keep the load, under normal operating conditions, balanced as close as practical for the average load across the phase wires.

**M. Feedback**

To avoid possible hazards to PLC employees, the customer shall not supply power to the electrical system of a building by any temporary means of wiring, such as an extension cord or with a generator without a state-approved transfer switch. Failure to comply with this paragraph may result in immediate disconnection of the service. WAC 296-46B-700, NEC 702.

**N. Power Quality**

1. The customer's use of electricity must not interfere with the quality of their own service, power supplied to other customers or the serving utility. The owner of the service causing the electrical disturbance is responsible for taking corrective action.
2. Motors starting at full voltage can cause voltage reductions that will cause lights to dim and electronic equipment to stop operating properly. The voltage reductions can affect customers in the general area of the motor being started. PLC requires installation of a soft start motor starter for all motors 10 HP and greater. Wye-delta motor starters are not allowed.

**O. Company Poles**

The customer shall not install **any** devices on PLC-owned poles. This includes both primary and secondary poles, and refers to not only devices electrical in nature, but also any advertisements, signs, notices, reflectors or similar objects. RCW 70.54.090 - A person violating this section is guilty of a misdemeanor.

---

SUBJECT:

**RESIDENTIAL METERING GUIDELINES FOR ELECTRIC SERVICE**

**P. Temporary Services**

1. Temporary electrical power shall be permitted during the period of construction, remodeling, maintenance, repair, or demolition of buildings, structures, equipment, or similar activities. The duration of Temporary Service Connection shall not exceed one (1) year.
2. Meter(s) shall be located to face the roadway, driveway or parking area, unless otherwise directed by PLC's Engineering Department.

**II. METER SOCKETS**

The customer is required to provide a meter socket or current transformer loop as specified of a type acceptable to PLC for the installation desired.

**A. Metering Voltages**

1. All low voltage metering shall be at the service voltage.
2. All high voltage services (600 volts and above) shall be metered in accordance with Electric Utility Service Equipment Requirements Committee (USERC) standards. Consult PLC for specific requirements.

**B. Mounting**

Sockets must be mounted level and plumb and be securely fastened to the structure.

**C. Openings and Drains**

Unused threaded or knockout openings must be closed with an approved plug locked in place from the inside. Metering equipment enclosures shall be weatherproof if outside.

**D. Termination**

An oxide inhibitor for stranded aluminum conductors is required for conductor termination. **Oxide inhibitor must not be used on copper conductors, meter terminals or socket jaws.**

**E. Safe Location**

1. You must provide a location for meters and metering equipment, which is acceptable to PLC, is readily accessible without risk of bodily harm to PLC employees and is free from vibration, corrosive atmosphere and abnormal temperatures. The equipment must be protected from damage and must not be installed over stairs or steps, under or over decks. Meters shall not be located in carports, breezeways, porches, or similar locations historically proven to have a

SUBJECT:

**RESIDENTIAL METERING GUIDELINES FOR ELECTRIC SERVICE**

high probability of becoming enclosed. If mounted in a balcony or platform area, the area must be served by a permanent stairway.

2. When an outside meter location is to be in a parking area, the meter must be so located that parked vehicles will not restrict meter accessibility. Meters installed in an area where there may be vehicular traffic must be protected adequately to prevent damage.
3. For new or enlarged services where vandalism may result in damage to our metering equipment, PLC may require that you install protective enclosures or devices.
4. Buildings

Meter location(s) shall be readily visible and accessible. The meter must maintain an unobstructed view by facing either the driveway or parking area or be located within four (4') feet of the corner of the building, only on side closest to the driveway or parking area. Contact PLC's Engineering Department for acceptable locations. See page 11 in the appendix for acceptable meter locations on buildings.

**NOTE: PLC reserves the right to require customers to relocate their meter base, at the customer's expense, if it is placed in an unacceptable location or becomes inaccessible due to actions or changes by the customer.**

**F. Remote Meter Bases**

PLC highly recommends installing a remote meterbase as long as it is located on the customer's property. Meter posts or pedestals shall be located adjacent to and between five feet (5') and ten feet (10') beyond the edge of the driveway accessing the property it serves. Remote meterbases must face the driveway, parking area, or roadway and be readily accessible. Meterbases shall not be installed on power poles.

**G. Meter Pedestals**

1. Wood pedestals must be fully pressured treated and shall be no smaller than four inches (4") by six inches (6"), be buried thirty-six inches (36") below final grade, and be compacted to near natural state.
2. Metal meter pedestals are not allowed.
3. A mobile home service disconnect must be located within sight of, and not more than thirty feet (30'), from an exterior wall of the mobile home it serves. NEC Article 550-23.

Exception: Some mobile homes may be exempt from this rule, provided they come equipped with approved service gear. Consult the Department of Labor & Industries for more information.

SUBJECT:

**RESIDENTIAL METERING GUIDELINES FOR ELECTRIC SERVICE**

**H. Clearances**

1. General

All meters must be readily removable; i.e., not plastered in or built-in. Recessed meter bases are not allowed.

2. Working Space

A level standing working space shall be provided and maintained in front of each metering installation. A clear and unobstructed working space shall be provided above this space. NEC 110-26.

- a. The width of the working space shall be sufficient to permit ready access to the metering equipment and in no case less than three feet (3'). The height of the working space shall be equal to the overall height of the metering installation and in no case less than seven feet, one inch (7'1"). The working space shall extend at least three feet (3') in front of the meter glass or cover, or the outermost metering enclosure and ten inches (10") from the meter centerline to any obstruction such as walls or ceilings. Refer to Meter Clearance Guide drawing, page 17.

**I. Meter Height**

A meter height of five and one-half to six feet (5-1/2 to 6') is preferred with the reference point being the center of the meter glass or cover. The meter height shall not be greater than six feet three inches (6'3") and not less than four feet (4'0") above the finished grade or floor below. **Exception:** Current (and instrument) transformer-rated meters shall not be more than six feet (6') or less than five feet (5') above finished grade or floor.

**J. Taps and Splices**

Taps and splices are not allowed in meter sockets.

**K. Unmetered Conductors**

Customer's unmetered service wires and metered load wires are not to be run in the same conduit, raceway or wiring gutter. Suitable barriers shall separate metered and unmetered wires. Metered wires from the customer's distribution section (branch circuits) shall not pass through sealable sections.

**L. Circuit Closing Devices**

1. Automatic or manual by-pass services are not allowed in residential services with the exception of Class 320 services.
2. **Residential** 400 ampere, 320-ampere continuous duty sockets (class 320), shall have a Manual Lever Type By-Pass circuit-closing device.
- 
-

SUBJECT:

**RESIDENTIAL METERING GUIDELINES FOR ELECTRIC SERVICE**

**M. Conductor Connection**

1. Where aluminum conductors are used for service entrance, the meter socket terminals must be approved for use with aluminum, and an oxide inhibitor shall be applied to the conductors.
2. The line side supply conductors to a meter must be connected to the top terminals, and the load side supply conductors shall be connected to the bottom terminals.
3. Where a socket-type meter is installed on the line side of the service entrance equipment, the grounded conductor shall be grounded within the socket and in such a manner that removal of meter will not disconnect such grounded connection from grounded service conductor.

**N. Meter Rings**

Meter rings will be replaced with locking devices. Ringless meter bases are not allowed for residential services (exception 320A services).

**III. SELF-CONTAINED METERS and SERVICES**

**A. Residential 200-Ampere Service**

A properly sized self-contained UL-approved four-jaw meter socket shall be installed. 200-amp service is the minimum size for new or altered residential services. Ringless meter bases are not allowed for residential services (exception 320A services).

**Exception:** Services smaller than the minimum 200 amp are allowed for temporary services, pump services, gates and other similar types of services approved by PLC's Engineering Department provided the service entrance conductors meet NEC Article 230 for minimum size.

**B. Residential 320-Ampere Service**

For services including but not exceeding 320 amperes continuous (400 ampere maximum), a PLC-approved 320-ampere meter socket **equipped with a manual bypass lever** shall be installed. Meterbases shall be labeled 400 ampere (320 ampere continuous) and shall be equivalent to a Milbank Model #U1797-X for underground service entrance. Meterbases with a continuous rating of 300 amperes or sockets for bolt-in meters are not acceptable.

SUBJECT:

**RESIDENTIAL METERING GUIDELINES FOR ELECTRIC SERVICE**

**IV. CURRENT TRANSFORMER METERING AND SERVICES**

**A. Residential Services 400 and 600-Amperes**

1. **PLC provided** current transformers and meter sockets shall be used and installed by the customer.
  2. PLC shall furnish and maintain all current transformers necessary for metering electric energy used by its members.
  3. Where current transformers are used, the customer shall provide and install an acceptable enclosure and conduit system between the enclosure and the meter socket. The customer shall install PLC-furnished meter socket(s) and current transformers. Wiring the meter socket to the current transformers shall be PLC's responsibility. It is PLC's policy that all CT cans must have landing pads for CT mounting. CT can doors must be hinged.
  4. Current transformers are required on all services that exceed 400 amps capacity.
  5. All residential services shall have the CT cabinet-mounted on the outside of the building, or a remote location approved by PLC.
  6. The cover of a current transformer cabinet shall be side-hinged, have provisions for locks and/or seals, and be removable. Permanent access shall be maintained which shall not block access to the enclosure nor block the cover from opening a minimum of ninety degrees (90°) from the front of the cabinet. The cabinet door when in the open position shall not conceal or interfere in the access to the meter socket. Hinges shall be permanent (welded or concealed) so they cannot be disassembled from the outside of the cabinet and allow the cover to be removed while in the closed position.
  7. Current transformer cabinets must contain only main service conductors, metering equipment, and secondary wiring and must not be used as junction box or gutter for the purpose of making taps, except as follows:
    - a. In a single family dwelling, three connections shall be permitted on the load side of the current transformers. The customer shall provide approved terminal lugs.
    - b. With the single exception of residential installations, all load conductors from a current transformer enclosure shall terminate either at a main disconnect switch or a UL-labeled bus gutter rated at or above the service AIC (fault duty) rating.
  8. **Mounting Height**
    - a. The mounting height of the current transformer enclosure shall not be higher than eight feet (8') to the top of the enclosure, from the floor or platform.
- 
-

SUBJECT:

**RESIDENTIAL METERING GUIDELINES FOR ELECTRIC SERVICE**

- b. The mounting height of the current transformer enclosure shall be no lower than eighteen inches (18") to the bottom of the enclosure, from the floor or working platform.

**Note:** If the enclosure is outdoors, the enclosure shall be of rain-tight construction and shall be a minimum of eighteen inches (18") above grade. The maximum height of eight feet (8') to the top of the enclosure still applies

**B. Secondary Wiring and Enclosure Requirements for Transformer-Rated Meters**

1. The customer shall provide for PLC's exclusive use a one and one-quarter inch (1-1/4") minimum trade size conduit between the metering enclosure and the meter socket. The maximum length of this conduit shall not exceed fifty feet (50'), be of metallic material, and contain no condulets.
2. Enclosures for single-phase current transformer services shall be a minimum size of twenty-four inches (24") wide by forty-eight inches (48") long by eleven inches (11") deep.

**C. Landing Pads**

All landing pads shall be of heavy-duty type with a minimum (AIC) fault duty rating of 50,000 amps rms symmetrical. They shall be UL-labeled and built to EUSERC standards. DWGS 328A, 328B.

SUBJECT:

### RESIDENTIAL METERING GUIDELINES FOR ELECTRIC SERVICE

<p><b>TAILBOARD</b></p> <p>FOREMAN: _____ DATE: _____</p> <p>FOREMAN: _____ DATE: _____</p>	<p><b>ASBUILT</b></p> <p>FOREMAN: _____ DATE: _____</p> <p>FOREMAN: _____ DATE: _____</p>	<p>Engineer: _____</p> <p>DATE: _____</p> <p>13115 Goodenough Drive N.W. P.O. Box 76 Gr. Harbor, WA 98335 (206) 857-5800</p>
<p><b>ACCEPTABLE METER LOCATIONS</b></p>		
<p>PROJECT: ACCEPTABLE METER LOCATIONS</p> <p>CLIENT: PLC CUSTOMERS</p> <p>W/O #: _____</p> <p>SCALE: _____</p>		



REVISED:	PAGE:
8-1-08	16 of 22

SUBJECT:

### RESIDENTIAL METERING GUIDELINES FOR ELECTRIC SERVICE

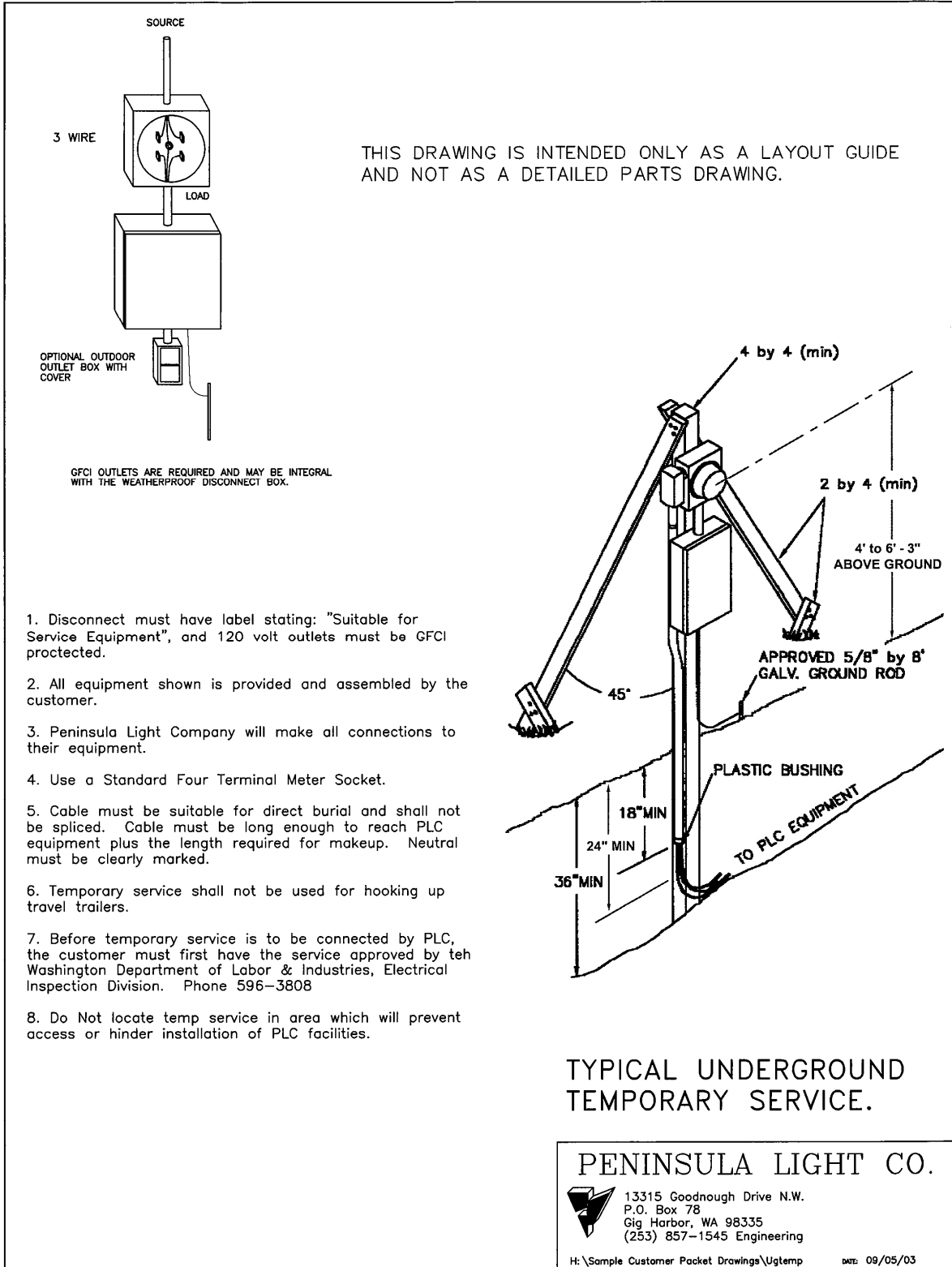

REVISED:	PAGE:
8-1-08	17 of 22

SUBJECT:

### RESIDENTIAL METERING GUIDELINES FOR ELECTRIC SERVICE

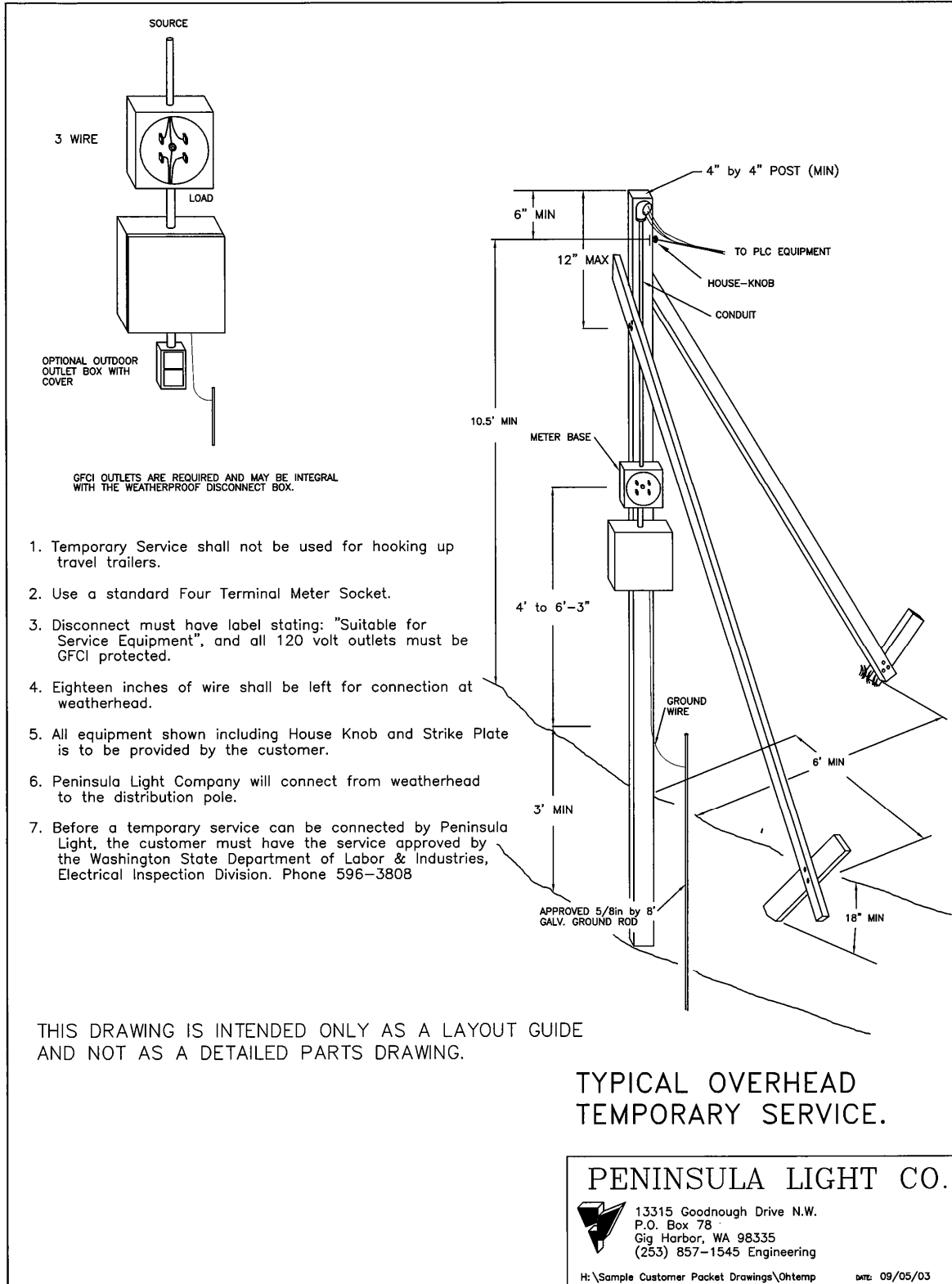

1. Temporary Service shall not be used for hooking up travel trailers.
2. Use a standard Four Terminal Meter Socket.
3. Disconnect must have label stating: "Suitable for Service Equipment", and all 120 volt outlets must be GFCI protected.
4. Eighteen inches of wire shall be left for connection at weatherhead.
5. All equipment shown including House Knob and Strike Plate is to be provided by the customer.
6. Peninsula Light Company will connect from weatherhead to the distribution pole.
7. Before a temporary service can be connected by Peninsula Light, the customer must have the service approved by the Washington State Department of Labor & Industries, Electrical Inspection Division. Phone 596-3808

THIS DRAWING IS INTENDED ONLY AS A LAYOUT GUIDE AND NOT AS A DETAILED PARTS DRAWING.

### TYPICAL OVERHEAD TEMPORARY SERVICE.

## PENINSULA LIGHT CO.



13315 Goodnough Drive N.W.  
P.O. Box 78  
Gig Harbor, WA 98335  
(253) 857-1545 Engineering

H:\Sample Customer Packet Drawings\Ohtemp

DATE: 09/05/03

REVISED:	PAGE:
8-1-08	18 of 22

SUBJECT:

### RESIDENTIAL METERING GUIDELINES FOR ELECTRIC SERVICE

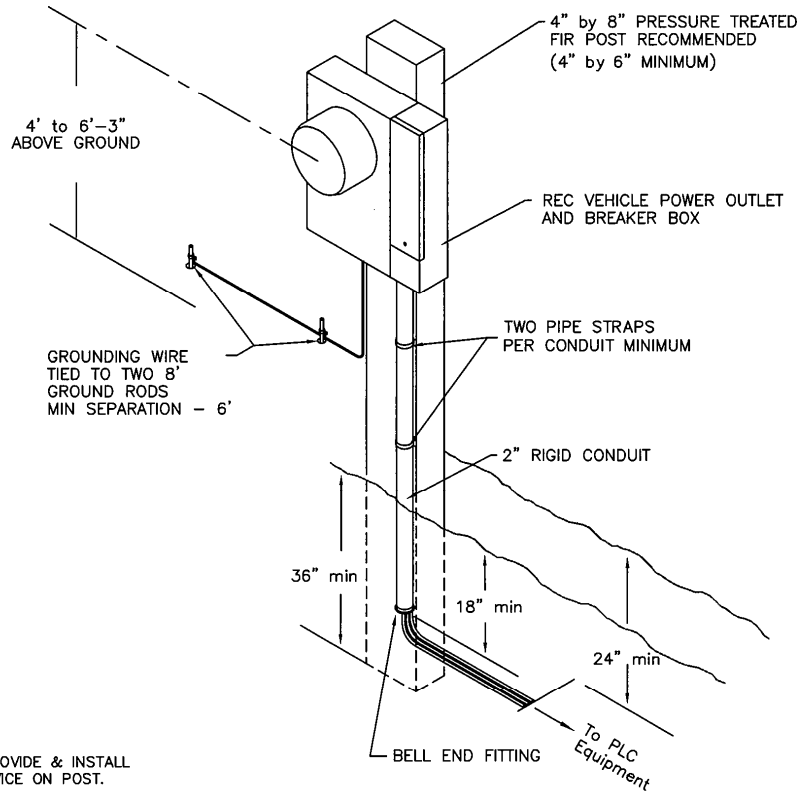

**NOTE:**

- 1) CUSTOMER TO PROVIDE & INSTALL ASSEMBLED SERVICE ON POST.
- 2) BEFORE THE SERVICE CAN BE CONNECTED BY THE POWER COMPANY, THE SERVICE MUST BE INSPECTED BY THE STATE ELECTRICAL INSPECTOR. PH # 596-3808
- 3) ALL 120 VOLT OUTLETS MUST BE G.F.C.I. PROTECTED. EXCEPT FOR THE SINGLE OUTLET USED FOR PLUGGING IN THE REC VEHICLE.
- 4) A STANDARD FOUR TERMINAL METER SOCKET IS REQUIRED.
- 5) AFTER SERVICE HAS BEEN STATE APPROVED, NOTIFY PENINSULA LIGHT FOR HOOK-UP. PH # 857-1545

THIS DRAWING IS INTENDED ONLY AS A LAYOUT GUIDE AND NOT AS A DETAILED PARTS DRAWING.

### TYPICAL UNDERGROUND REC VEHICLE SERVICE

### PENINSULA LIGHT CO.



13315 Goodnough Drive N.W.  
P.O. Box 78  
Gig Harbor, WA 98335  
(253) 857-1545 Engineering

H:\Sample Customer Packet Drawings\Fvugspec

DATE: 09/05/03

REVISED:	PAGE:
8-1-08	19 of 22

SUBJECT:

### RESIDENTIAL METERING GUIDELINES FOR ELECTRIC SERVICE

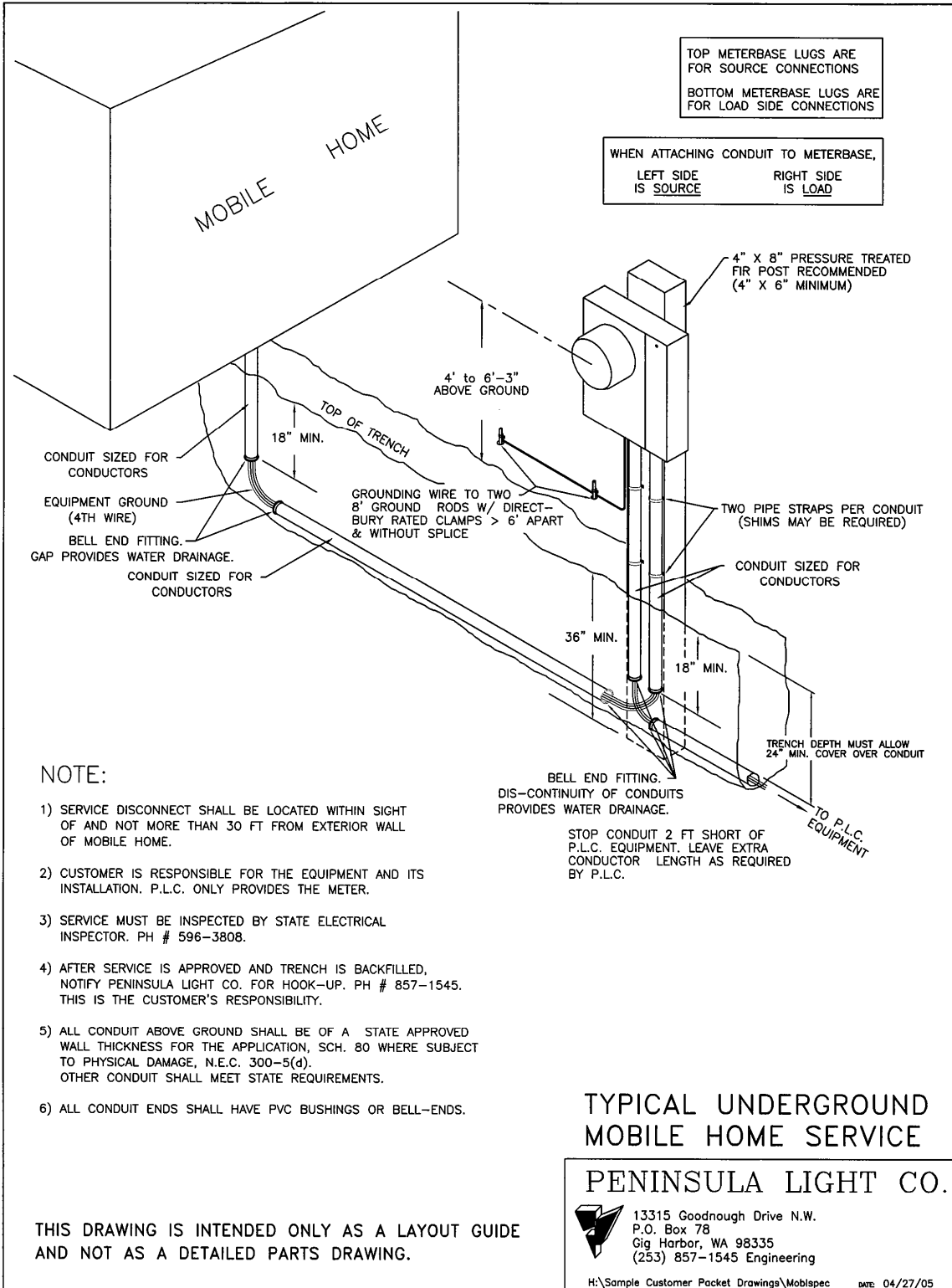

REVISED:	PAGE:
8-1-08	20 of 22

SUBJECT:

### RESIDENTIAL METERING GUIDELINES FOR ELECTRIC SERVICE

THIS DRAWING IS INTENDED ONLY AS A LAYOUT GUIDE  
AND NOT AS A DETAILED PARTS DRAWING.

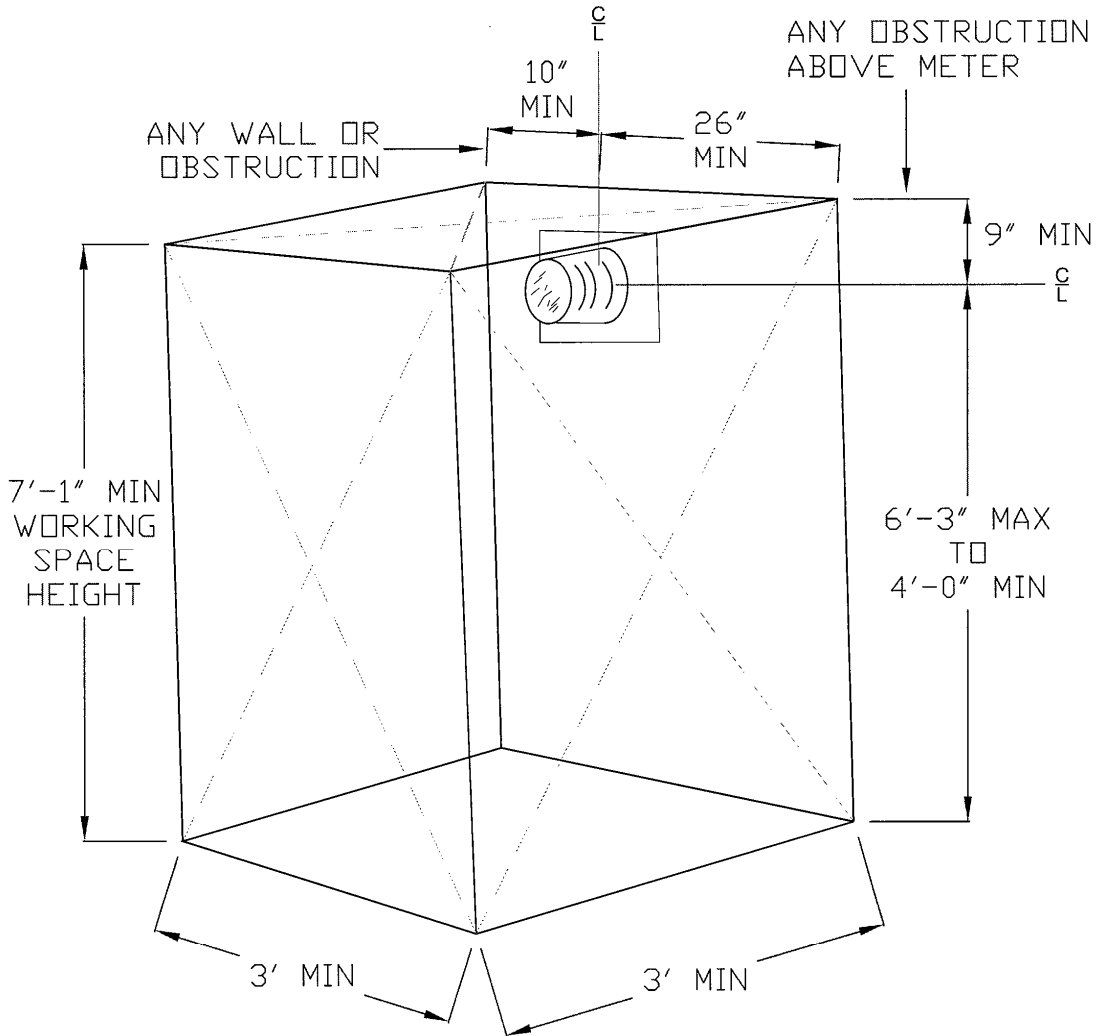

### METER CLEARANCE GUIDE

#### PENINSULA LIGHT CO.



13315 Goodnough Drive N.W.  
P.O. Box 78  
Gig Harbor, WA 98335  
(253) 857-1545 Engineering

DATE: 10/07/03

H:\Sample Customer Packet Drawings\meterclearance.dwg

REVISED:	PAGE:
8-1-08	21 of 22

SUBJECT:

### RESIDENTIAL METERING GUIDELINES FOR ELECTRIC SERVICE

#### SINGLE-PHASE LANDING PADS WITHOUT LUGS

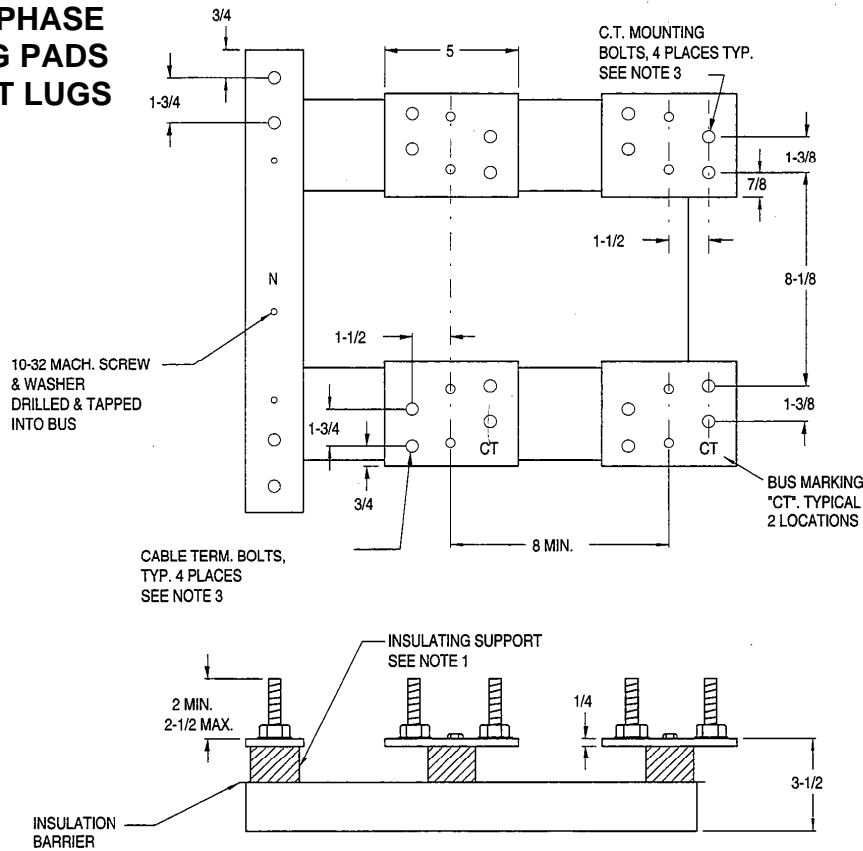

ALL DIMENSIONS SHOWN ARE IN INCHES

**NOTES:**

1. Insulated supports shall be rated for the serving voltage and have sufficient mechanical strength for the application.
2. Mounting base accepts bar type current transformers only.
3. Two 1/2 inch steel bolts shall be provided for each cable terminating and current-transformer mounting position. Each bolt shall be furnished with a spring washer and a nut. The spring washer may be either a cone-type (belleville) or a split-ring washer and a flat washer. Bolts shall be secured in place and spaced as shown. All parts shall be plated to prevent corrosion.
4. For applications, see Drawings 313, 314, and 316.

REV.	DATE	DESCRIPTION
1	08/92	NEW DRAWING PER - PROJECT 910201
2	08/93	REVISED FOR CONSISTENCY WITH DRAWING 347 - PROJECT 2F 8/93
3	05/96	REVISED TO CLARIFY STUD REQUIREMENTS- PROJECT 960201
SCALE		<b>CURRENT-TRANSFORMER MOUNTING BASE</b> <b>SINGLE-PHASE OR THREE-PHASE THREE-WIRE</b> <b>400 AMPERES MAXIMUM 0-600 VOLTS</b> <b>ELECTRIC UTILITY SERVICE EQUIPMENT REQUIREMENTS COMMITTEE</b>
DATE		
05/96		SH 1 OF 1 SH
		DWG NO
		328A
		REV.
		3

REVISED:	PAGE:
8-1-08	22 of 22

SUBJECT:

### RESIDENTIAL METERING GUIDELINES FOR ELECTRIC SERVICE

#### SINGLE-PHASE LANDING PADS WITH LUGS

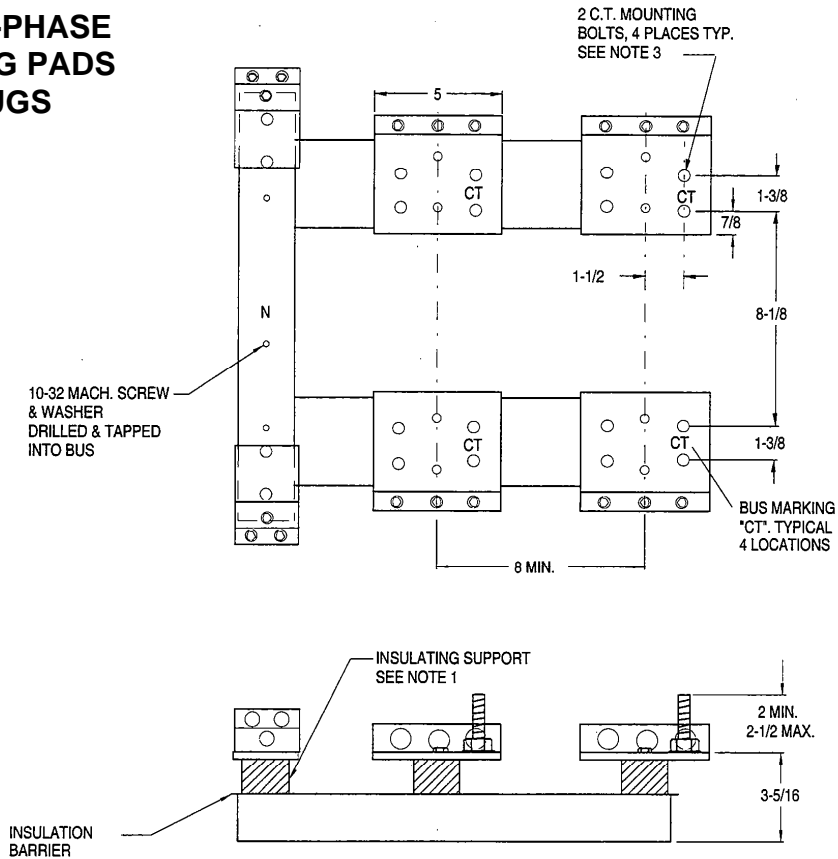

**NOTES:**

1. Mounting base accepts bar type current transformers only.
2. Two 1/2 inch steel bolts shall be provided for each current-transformer mounting position. Each bolt shall be secured in place and furnished with a spring washer and a nut. The spring washer may be either a cone-type (belleville) or a split-ring washer and a flat washer. All parts shall be plated to prevent corrosion.
3. Termination's for service conductors shall be three-position, aluminum-bodied mechanical lugs with a range accepting one No. 4 AWG through 600 Kcmil conductor or two No. 1 AWG through 250 Kcmil conductors.
4. For applications, see Drawings 313, 314, and 316.

REV.	DATE	DESCRIPTION
	08/97	NEW DRAWING
SCALE		<b>CURRENT-TRANSFORMER MOUNTING BASE</b> <b>SINGLE-PHASE OR THREE-PHASE THREE-WIRE</b> <b>400 AMPERES MAXIMUM 0-600 VOLTS</b> <b>ELECTRIC UTILITY SERVICE EQUIPMENT REQUIREMENTS COMMITTEE</b>
DATE		
08/97		SH 1 OF 1 SH
		DWG NO 328B
		REV.